

**NOTE:**

1. Seal Kit P/N: 60-5623-00
2. Face Seal P/N: 39-0562-30
3. Seal Mounting Tool P/N: AT-5603-00
4. Thread-In Mounting Tool P/N: AT-5613-00
5. Instructions are on IS5633

**COUPLING ELEMENT  
THREAD-IN BODY  
SHOWN WITH  
SLIP-IN INSTALLED**

Torque to  
11 lb\*ft

**SLIP-IN**

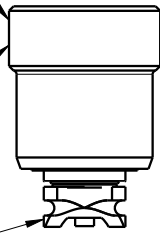

**SLIP-IN**

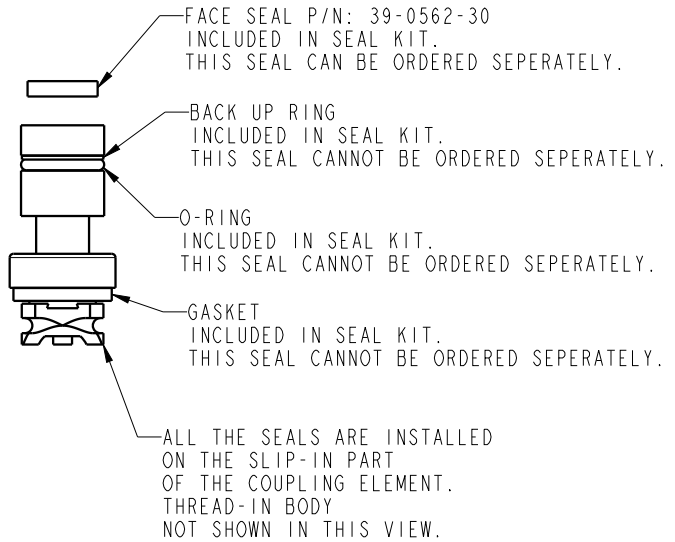

**PARTS  
LIST**



VEKTEK, INC.  
1334 E. SIXTH AVE. P.O. BOX 625  
EMPORIA, KS. 66801 U.S.A.

ASSEMBLIES AFFECTED

56-1023-00  
56-2023-00

PARTS LIST, COUPLING ELEMENTS, DEPRESS, ND3

SIZE  
A PL5635

REV  
C

SHEET 1 OF 1

C	3840	RELEASE	JDW	05/28/19
REV	IN ACCORDANCE WITH ECN	EFFECTIVE DATE	REVISED BY	DATE
DRW BY:	Twa	<b>DRAWING STATUS: Released</b>		
DATE:	8/18/16	PRODUCTION APPROVED FOR RELEASED STATUS ONLY		

1

2

### REPLACING THE FACE SEAL:

1. The Coupling Mechanisms (2) are designed so that the face seal (1) can be replaced without having to removed the Mechanism (2) from its cavity.
2. Using a scribe or a sharp pick, pull the old face seal (1) out from the pilot groove.
3. Insert the new face seal (1) into the tip of the Seal Mounting Tool (P/N: AT-5603-00).
4. Taking the Seal Mounting Tool (P/N: AT-5603-00) in your hand, press the face seal (1) until it's flush in the pilot groove, keeping the Seal Mounting Tool (P/N: AT-5603-00) axially aligned to the Mechanism (2).

B

B

A

A

THREAD-IN

SLIP-IN

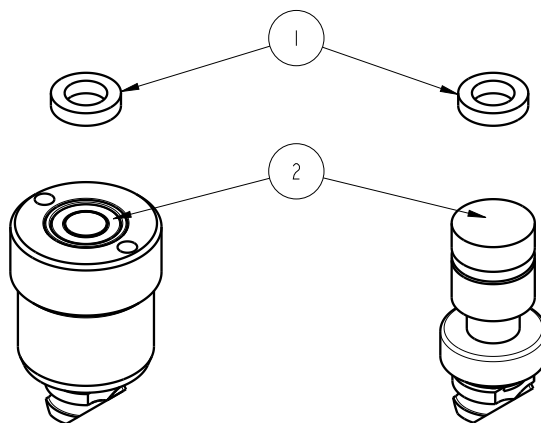

### INSTALLATION INSTRUCTIONS



VEKTEK, INC.  
 1334 E. SIXTH AVE. P.O. BOX 625  
 EMPORIA, KS. 66801 U.S.A.

A	3077	RELEASE	TWA	8/19/16
REV	IN ACCORDANCE WITH ECN	EFFECTIVE DATE	REVISED BY	DATE
DRW BY:	TWA	<b>DRAWING STATUS: Design</b>		
DATE:	8/19/16	PRODUCTION APPROVED FOR RELEASED STATUS ONLY		

ASSEMBLIES AFFECTED
56-1013-00 56-2013-00 56-1023-00 56-2023-00

INSTRUCTION SHEET, COUPLING ELEMENTS, ND3	
SIZE A	IS5633
REV A	

1

2

FORM FEG041-IS-ASIZE, REV. B

SHEET 1 OF 1